

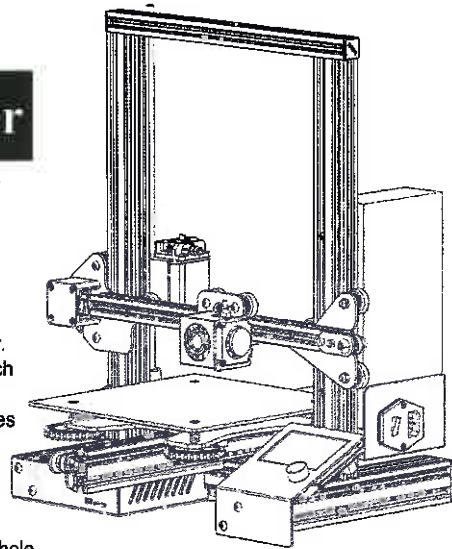

# Ender-3 3D Printer

## Instructions for assembly



- ◆ This guide is for the Ender-3 3D printer.
- ◆ Select the correct input voltage to match your local mains (220V or 110V).
- ◆ Because of software/hardware upgrades and model differences, new revisions may not be listed in this guide.
- ◆ Detailed instructions for use are available on the SD card.
- ◆ Please plug the Power cord into a three-hole power jack.



Facebook QR code

Shenzhen Creality3D Technology CO.,LTD.

Official Website: [www.creality3d.cn](http://www.creality3d.cn)

Company Address: 12F, Building No.3, Jinchengyuan Industrial Area, Hua'an Road, Daxiang, Longhua, Shenzhen, Guangdong Province



## List 1

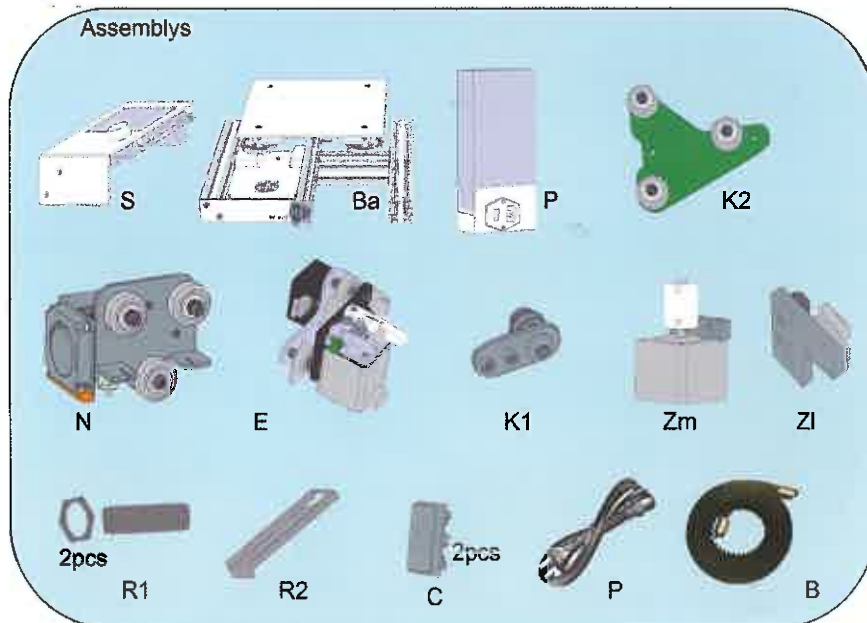

## List 2

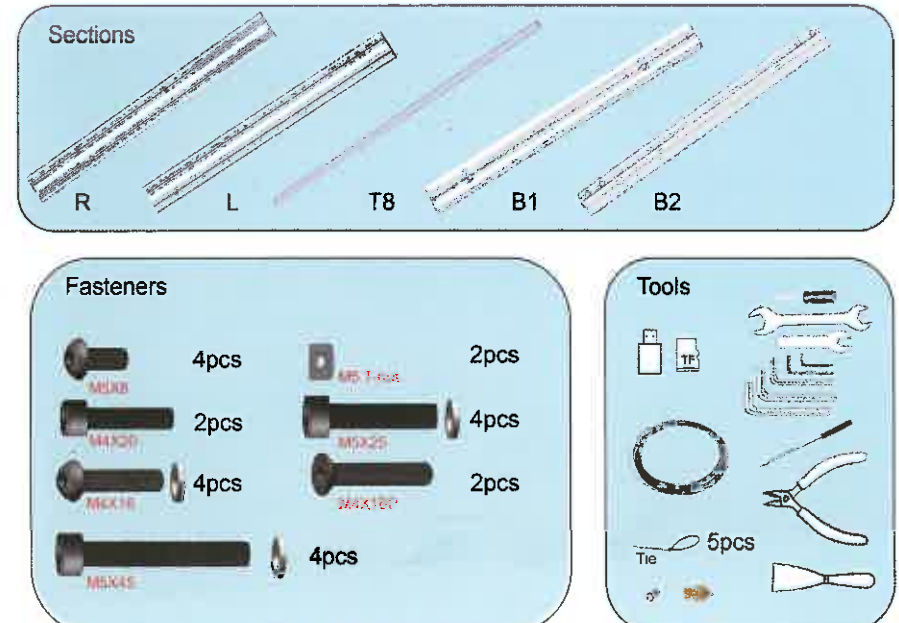

### Step 1

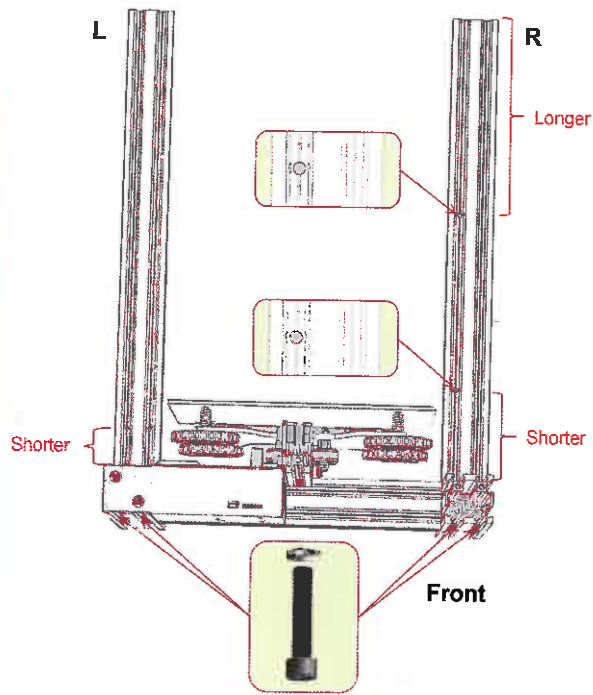
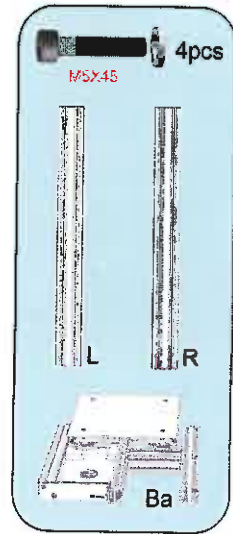

### Step 2

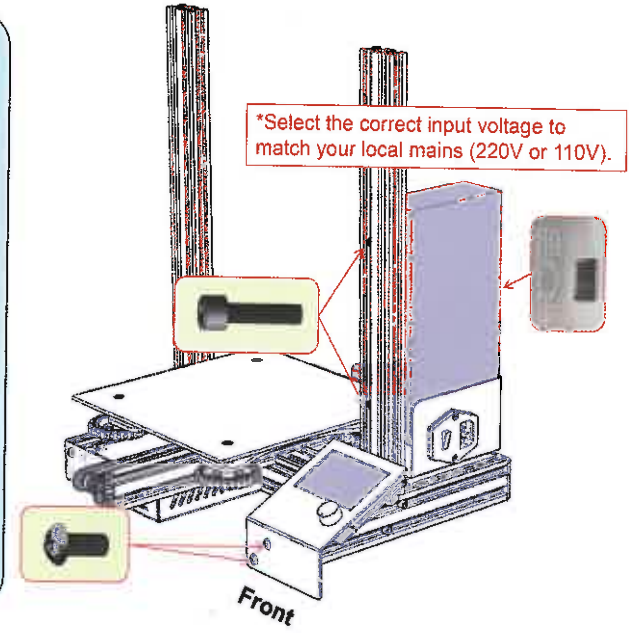

### Step 3

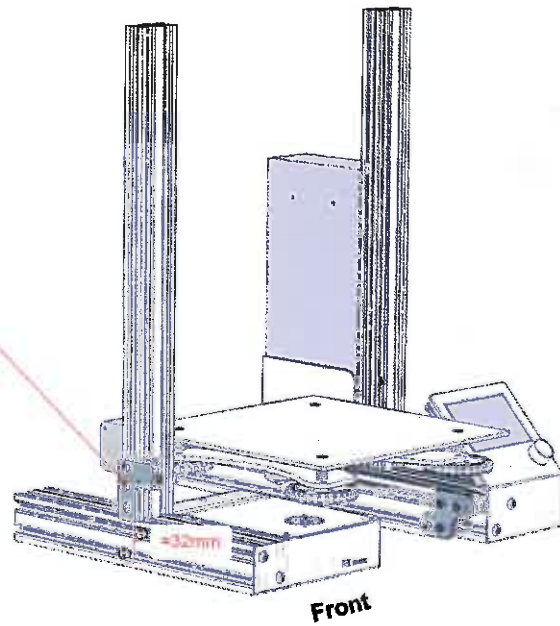
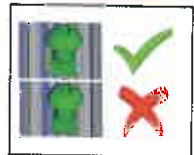
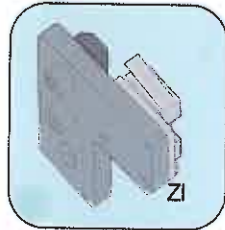

### Step 4

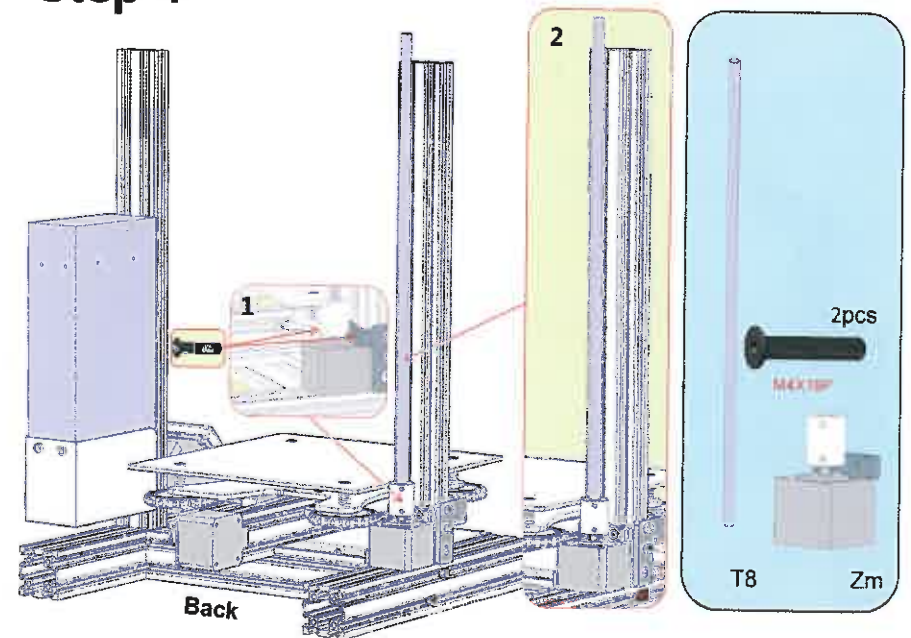

## Step 5

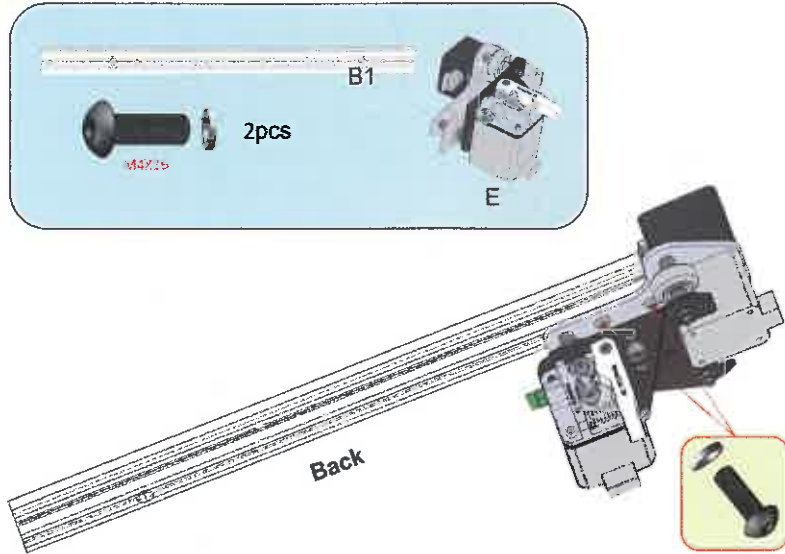

## Step 6

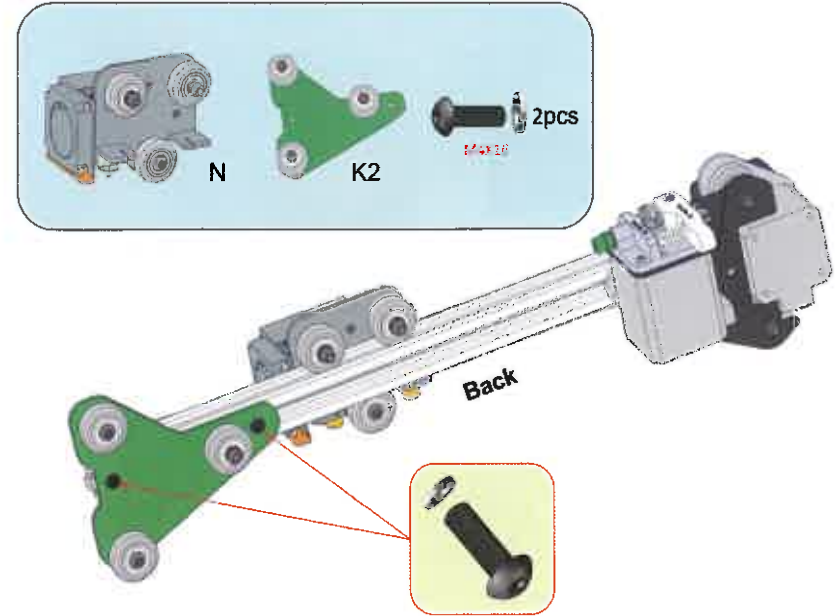

## Step 7

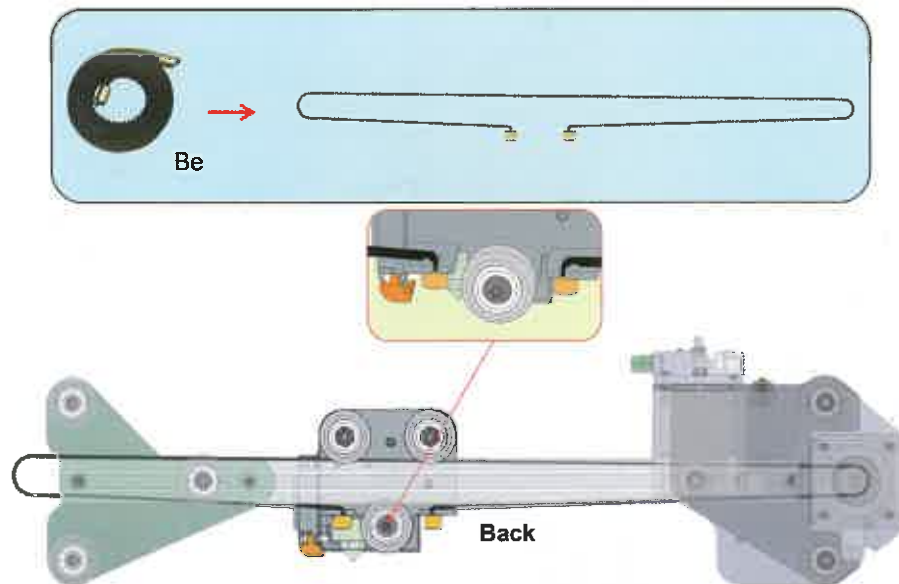

## Step 8

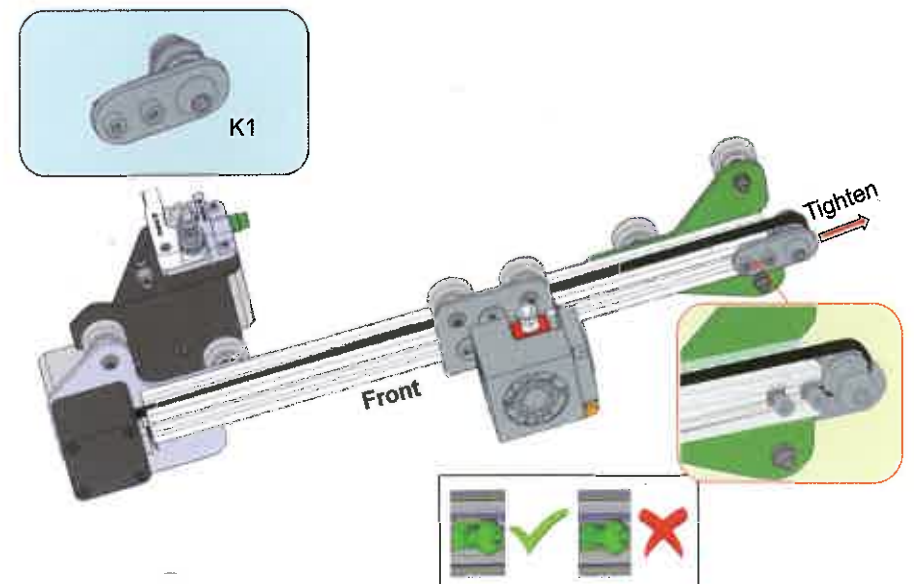

## Step 9

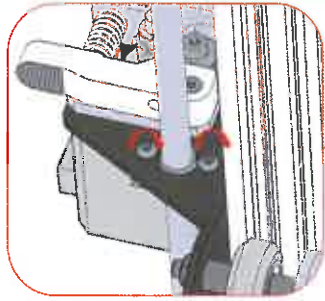
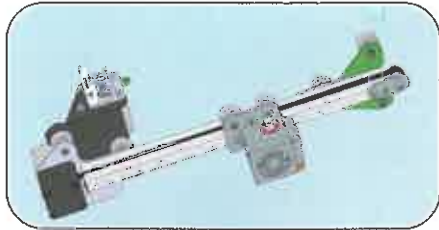

\*Don't tighten it too tight

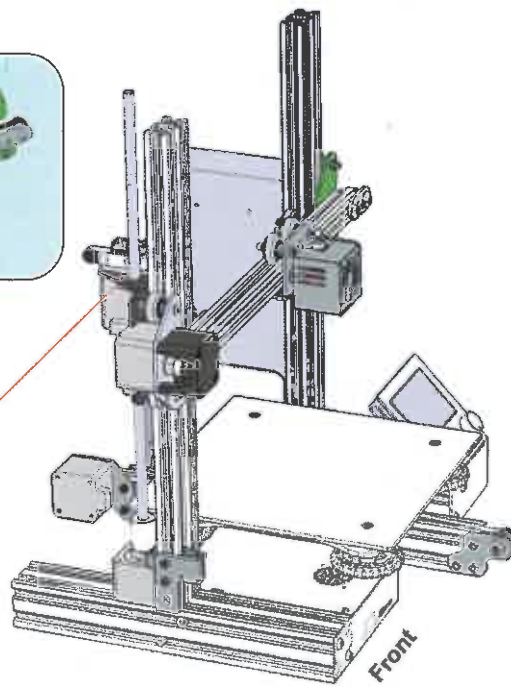

## Step 10

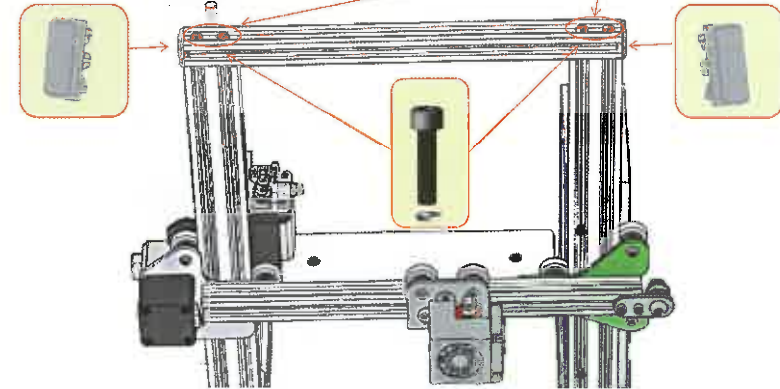

## Step 11

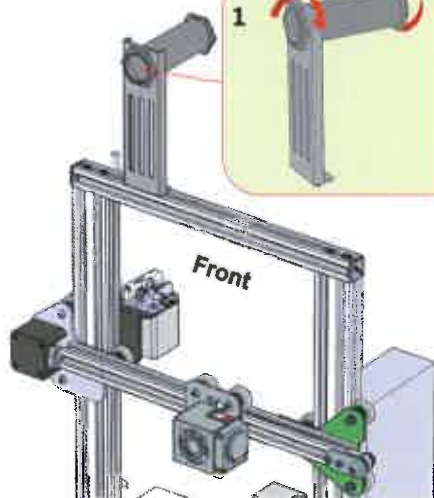
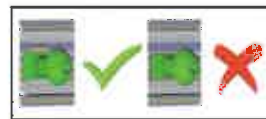
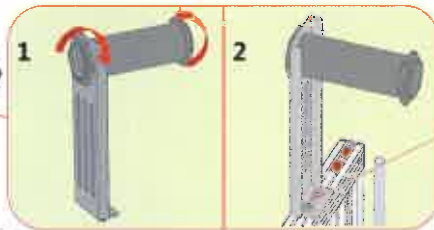

## Step 12

